

360 Outdoors

Brand Guide



Fonts/Type Face

Headline:

Rockwell Bold (16-72pts)

The Quick Brown Fox Jumps Over The Lazy Dog

ABCDEFGHIJKLMNOPQRSTUVWXYZ

abcdefghijklmnopqrstuvwxyz

1234567890

Sub headlines:

Lato Bold/Heavy (14-60pts)

The Quick Brown Fox Jumps Over The Lazy Dog

ABCDEFGHIJKLMNOPQRSTUVWXYZ

abcdefghijklmnopqrstuvwxyz

1234567890

Body copy:

Merriweather Regular/Bold (for keywords and emphasis) (6-14pts)

The Quick Brown Fox Jumps Over The Lazy Dog

ABCDEFGHIJKLMNOPQRSTUVWXYZ

abcdefghijklmnopqrstuvwxyz

1234567890

COLORS



Forrest Green

CMYK: 75, 43, 77, 35

RGB: 58,90, 64

HEX: #355A40



Ultra Violet

CMYK: 19, 27, 0, 51

RGB: 101, 90, 124

HEX: #655A7C



Copper

CMYK: 0, 38, 72, 28

RGB: 184, 115, 51

HEX: B87333

LOGO

A brand is the unique identity of a business, product, or individual that encompasses its visual elements, values, messaging, and overall reputation. It's how a company presents itself to the world and how customers perceive it, shaping their emotional connection and trust. A brand is more than just a logo or tagline—it's a cohesive experience that reflects the company's mission and personality across all touchpoints, from marketing materials to customer service. Consistency in branding fosters recognition, loyalty, and differentiation in a competitive market.



Stacked Black



Mark Black



Word Mark

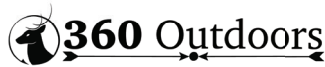

Wide Black



Stacked 4c



Mark 2c



Word Mark 4c



Wide 4c



Stacked Reversed



Wide Reversed



Mark Reversed



Word Mark Reversed

LOGO

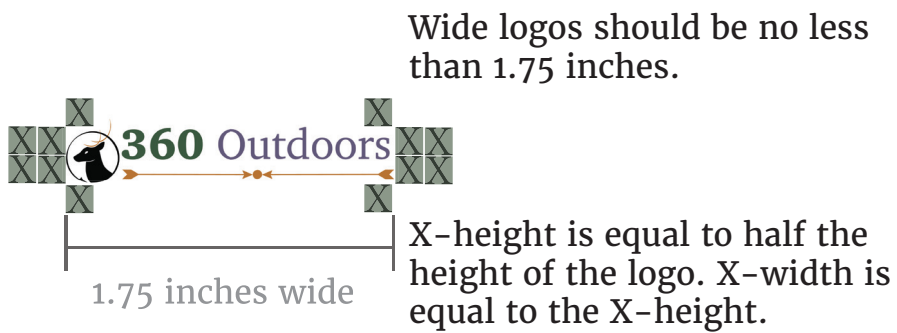
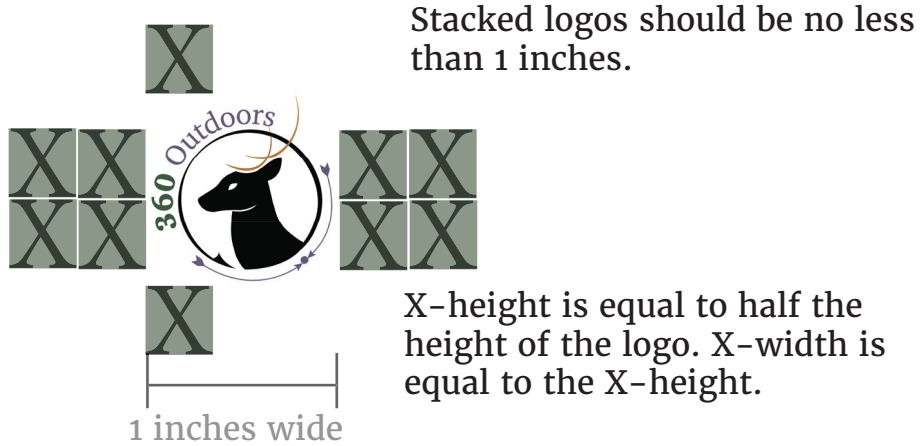

No logos should be stretched or distorted in any way.